

MIXPAC™ DM2X 200

200 ML CARTRIDGE DISPENSER

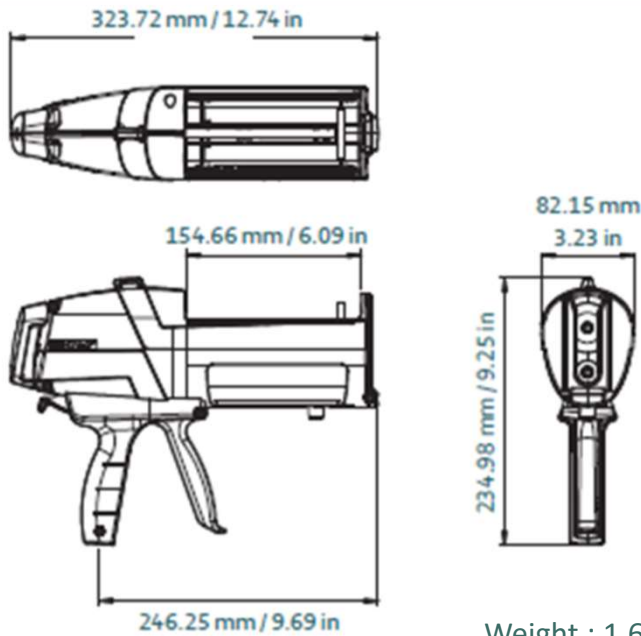

Weight : 1,6kg

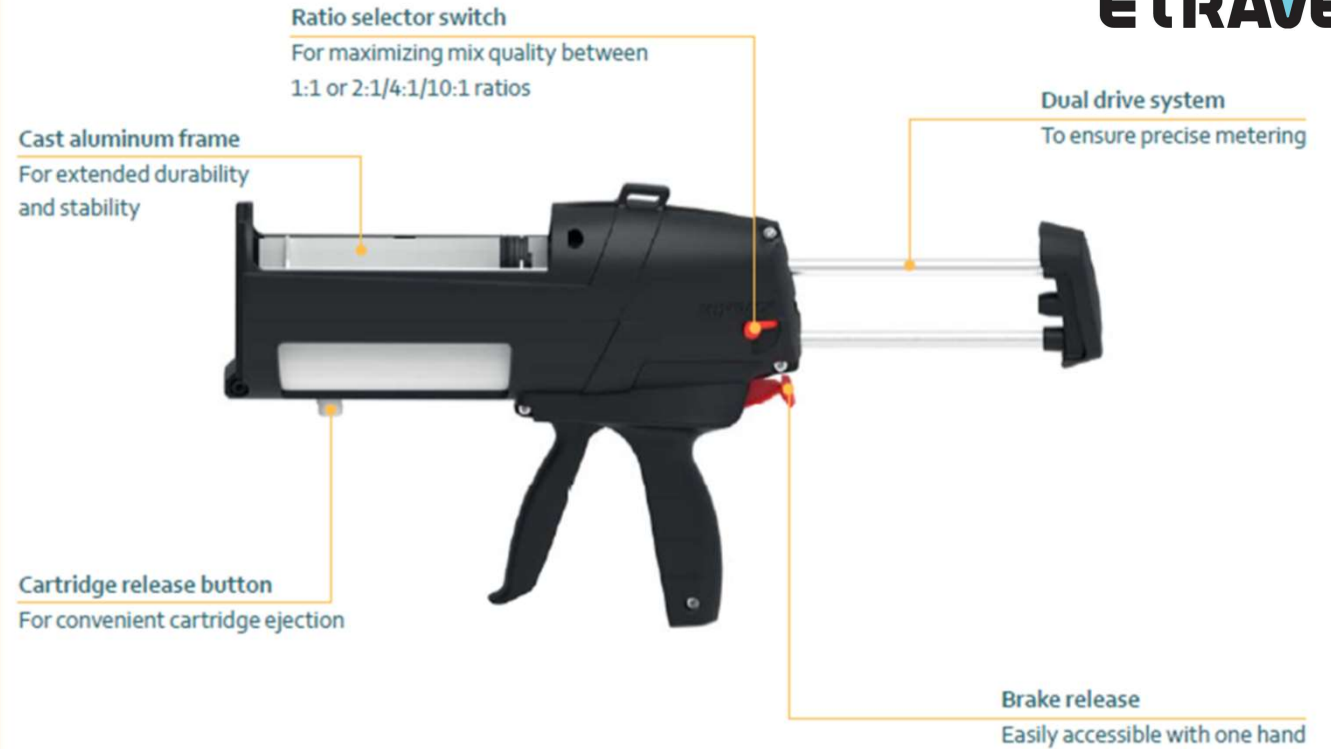

COMPATIBILITY

C-system
F-system

Etraves Item	Designation	Medmix Item	Ratio 1:1	Ratio 2:1	Ratio 4:1	Ratio 10:1
21 957	DM2X 200-01-52-01	165803	✓	✓		
21 958	DM2X 200-04-52-01	165804			✓	
21 959	DM2X 200-10-52-01	165805				✓

BENEFITS

- Universal conversion kits with interchangeable cartridge trays and plungers
- High thrust ratio
- Ergonomically designed
- Easy to dispense high viscosity products
- Maximum comfort and fatigue-free operation

MIXPAC™ DP2X 200

200 ML CARTRIDGE DISPENSER

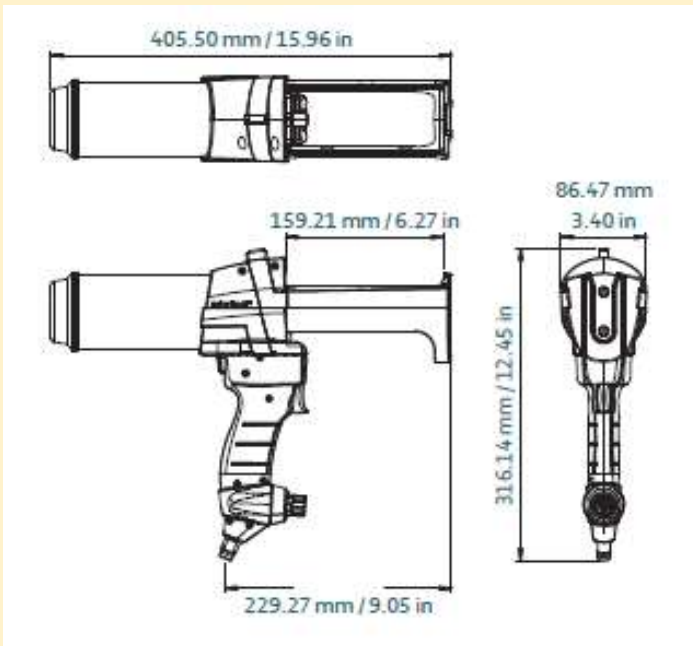

- Weight : 1,76kg
- Air inlet: ¼ in NPT
- Max operating pressure: 6,8 bar / 100 psi

COMPATIBILITY

C-system
F-system

Etraves Item	Designation	Medmix Item	Ratio 1:1	Ratio 2:1	Ratio 4:1	Ratio 10:1
21 442	DP2X 200-01-25-01	165860	✓	✓		
21 443	DP2X 200-04-25-01	165861			✓	
21 444	DP2X 200-10-25-01	165862				✓



BENEFITS

- High precision & dispensing accuracy
- Ergonomically designed
- No oozing or dripping
- Fatigue-free operation for longer periods of time

MIXPAC™ DM2X 400

400 ML CARTRIDGE DISPENSER

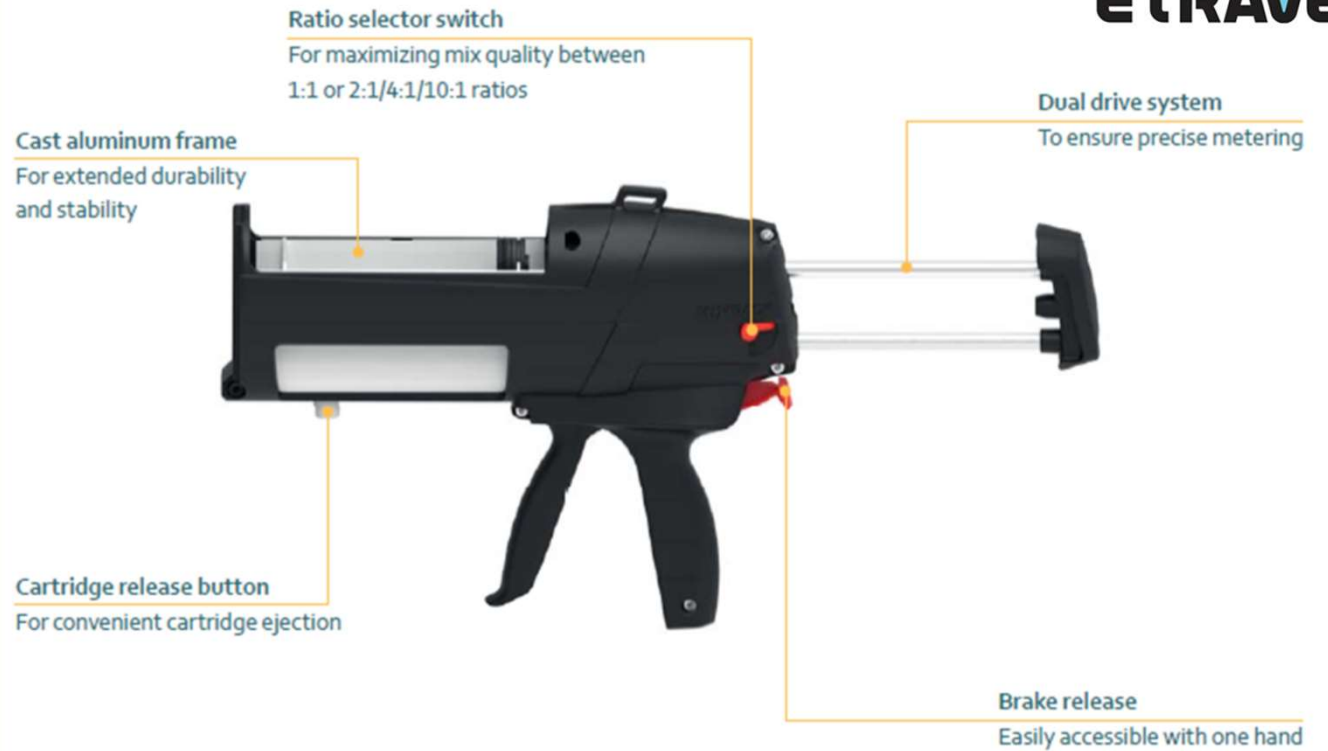
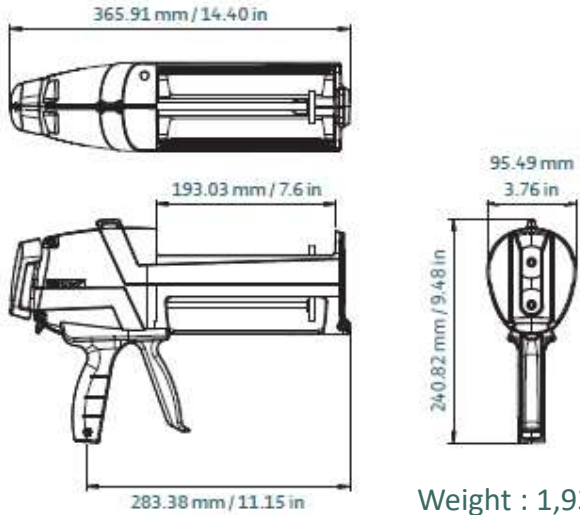

COMPATIBILITY

C-system
F-system

Etraves Item	Designation	Medmix Item	Ratio 1:1	Ratio 2:1	Ratio 4:1	Ratio 10:1
21 960	DM2X 400-01-60-01	165807	✓	✓		
	DM2X 400-04-60-01	165808			✓	
	DM2X 400-10-60-01	165809				✓

BENEFITS

- Universal conversion kits with interchangeable cartridge trays and plungers
- High thrust ratio
- Ergonomically designed
- Easy to dispense high viscosity products
- Maximum comfort and fatigue-free operation

COX VBM 400MR

400 ML CARTRIDGE DISPENSER

The VBM 400 MR 2- component manual dispenser has a high-powered 18:1 mechanism designed for use with **medium to high viscosity** sealants and adhesives.

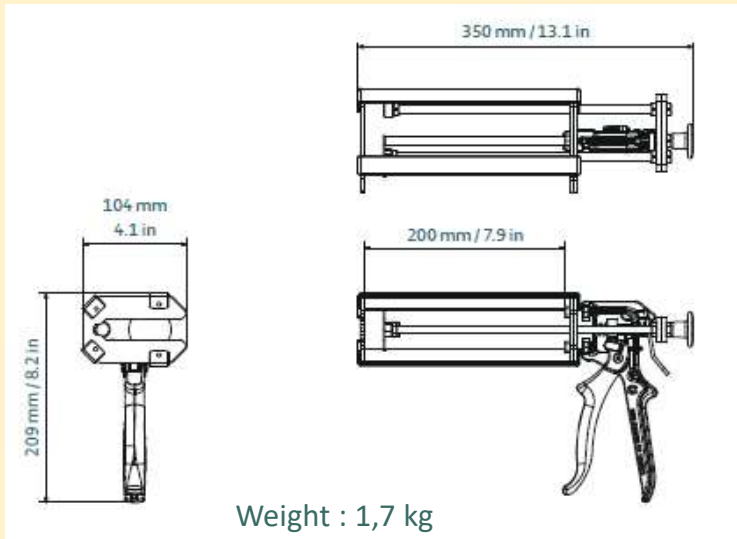

COMPATIBILITY C-system & BlueLine

Etraves Item	Designation	Medmix Item	Ratio 1:1	Ratio 2:1	Ratio 4:1	Ratio 10:1
17 060	DM2C 400-MR-r18-111	177675				✓

other ratios are available - on request

BENEFITS

- High quality cast aluminum handle
- For day long comfortable use
- For efficient dispensing

COX VBM 400X MR

400 ML CARTRIDGE DISPENSER

The VBM 400X MR 2- component manual dispenser has a high-powered 25:1 mechanism while the snap fit cartridge straps gives optimal cartridge support and fit.

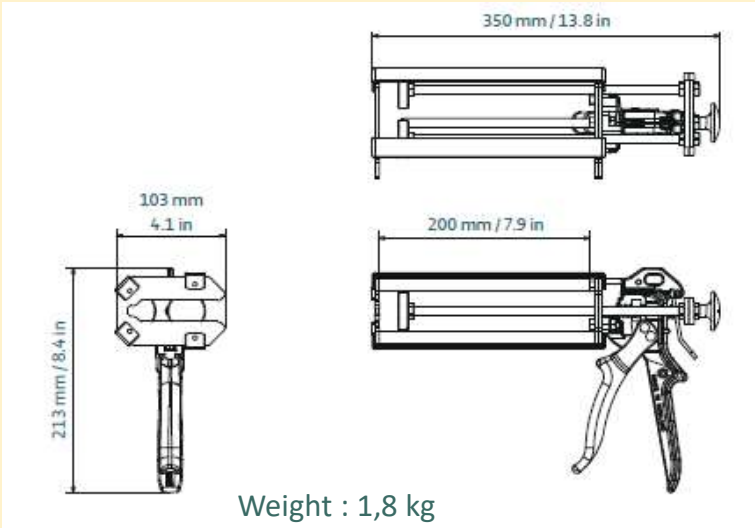

COMPATIBILITY

C-system & BlueLine

Etraves Item	Designation	Medmix Item	Ratio 1:1	Ratio 2:1	Ratio 4:1	Ratio 10:1
22 375	DM2C 400-10-r25-101	177676				✓

other ratios are available - on request

BENEFITS

- High quality cast aluminum handle
- For day long comfortable use
- For efficient dispensing

MIXPAC™ DP2X 400

400 ML CARTRIDGE DISPENSER

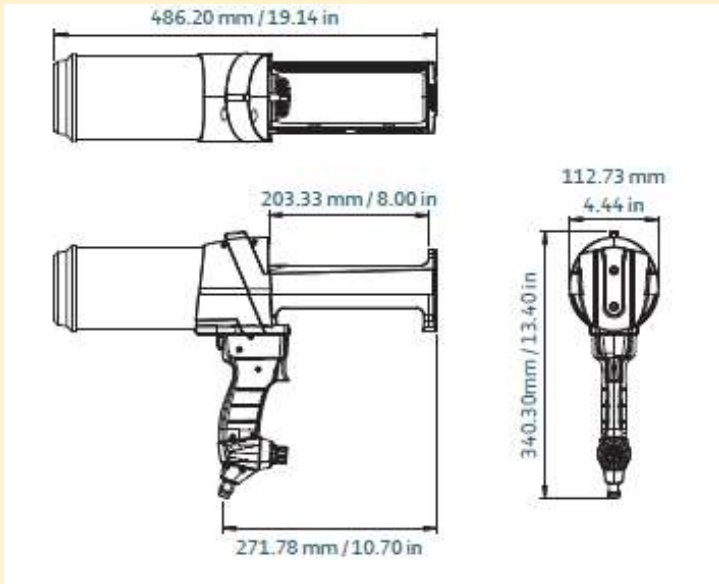

- Weight : 2,66kg
- Air inlet: ¼ in NPT
- Max operating pressure: 6,8 bar / 100 psi

COMPATIBILITY

C-system
F-system

Etraves Item	Designation	Medmix Item	Ratio 1:1	Ratio 2:1	Ratio 4:1	Ratio 10:1
21 445	DP2X 400-01-50-01	165864	✓	✓		
21 446	DP2X 400-04-50-01	165865			✓	
21 447	DP2X 400-10-50-01	165866				✓



BENEFITS

- High precision & dispensing accuracy
- Ergonomically designed
- No oozing or dripping
- Fatigue-free operation for longer periods of time