

AIRFLOW 1 CBA25

50ML CARTRIDGE DISPENSER

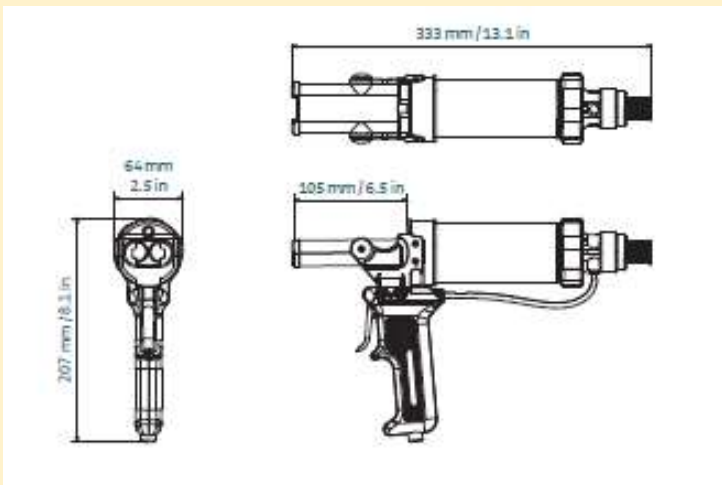

Weight : 0,75kg
 Max. pressure : 5,0 bar
 Air consumption : 40l/min



COMPATIBILITY

A-system
 B-system

Etraves Item	Designation	Medmix Item	Ratio 1:1	Ratio 2:1	Ratio 4:1	Ratio 10:1
178	DP2C 050-01-150-101	177747	✓			

BENEFITS

- Ensures precise controlled pressure
- For effortless use and minimum fatigue
- Adjustable air regulator
- Prevents run-on